



MILLER & CHALK
www.millerandchalk.com

Measuring Guide

ROMAN BLINDS

INSIDE THE RECESS

STEP 1:

Measure the width inside the recess in three places. Your window may not be square therefore take the smallest width measurements and subtract 1 cm. This is your finished width.

STEP 2:

Measure the length of your window in three places. Again choose the smallest measurement. This is your finished length.

TIP:

Make sure there are no obstructions in the way of your blind. Need help? Contact us for more guidance.

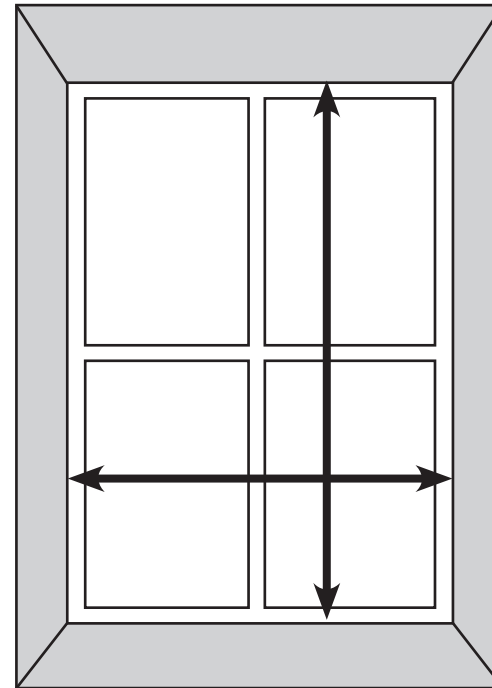

Measuring Guide

ROMAN BLINDS

OUTSIDE THE RECESS

STEP 1:

Decide where you would like your blind to hang. We recommend hanging your blind approximately 15cm above the recess. The bottom of the blind should either sit on the sill (if it projects) or approximately 10cm below the sill.

Measure from the top of the blind position to the desired length. Do this in three places and use the smallest measurement. This will be your finished length.

STEP 2:

Measure the recess width and add on 5cm either side. This is your finished width.

TIP:

Make sure there are no obstructions in the way of your blind. Need help? Contact us for more guidance.

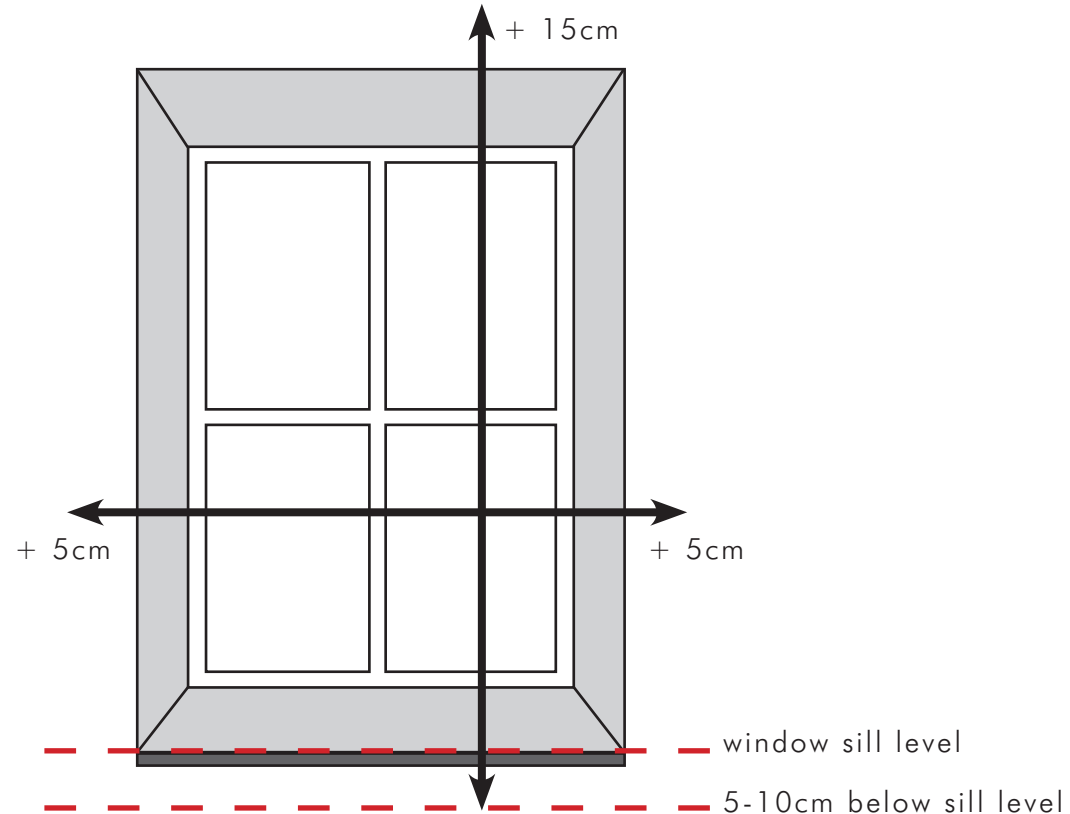

Measuring Guide

CURTAINS

STEP 1:

Measure the width. If you are using a curtain pole, measure the pole length between the end finials. If you are using a curtain track, simply measure the width of the track.

STEP 2:

Measure the length. If using a curtain pole, measure from the small metal ring at the bottom of each curtain ring. If using a track, measure from the top of the track. We recommend lining up the top of your curtains with the top of the track.

For floor length curtains, measure from your desired position to the floor or 1 cm above.

For kicked length curtains, add on 3cm to your drop.

TIP:

Always hang your curtain pole or track first before measuring for your curtains. Measure the length in three places and choose the length that best suits.

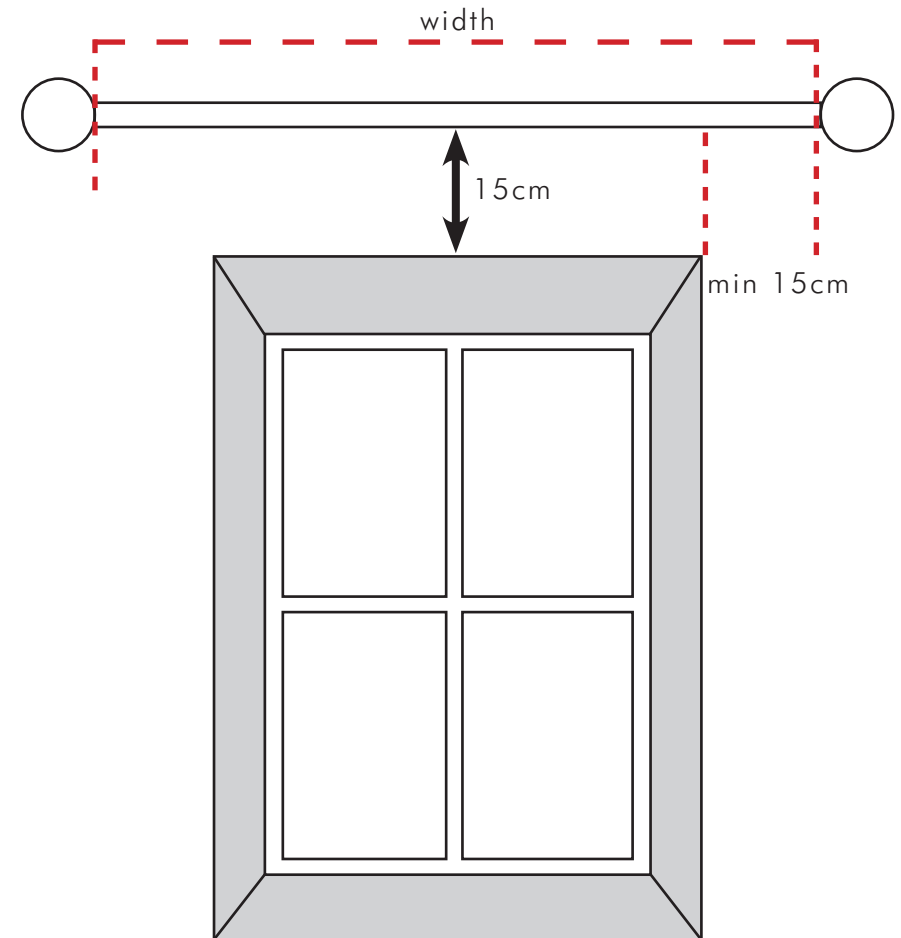

Roman Blinds & Curtains

Hand Sewn

Our roman blinds and curtains are hand sewn using traditional techniques to create a durable neat finish. The advantage of hand sewn roman blinds and curtains is that there are no visible stitches on the face of the finished product. This creates a really clean high end look. We have several different lining options:

- Cotton Lining
- Blackout Lining
- Interlining **Recommended**

We also have a variety of different coloured linings to choose from and we can advise on the best match for your face fabric. We recommend using interlining for all blinds and curtains and we quote for this as standard. Interlining is a soft thick fabric that is sewn inbetween the face fabric and lining. The advantages of using interlining is it acts as insulation, it helps against UV damage and it adds a luxurious thickness.

“ This space is not long enough for me to write the 5* rating you deserve! ”

Jacci

